

CONVEYORS SLIDEBEDS CHAIN BELT ROLLER CHAIN STEEL BELT FLUFFERS
CART DUMBERS TROMMELS AIR CLASSIFIERS SPECIAL SAFETY SYSTEMS COMPLETE SORT SYSTEMS

Karl W. Schmidt is proud to partner with Associates that supply our clients the finest in assessorial equipment.

DOUBLE FLUFFER

The Double Fluffer is designed and manufactured to receive paper and paper product materials. The Fluffer may also be utilized as a perforator on recyclable plastic containers.

The Fluffer box is fabricated from structural steel shapes and heavy steel plates. Upper and lower frames are 4" ship/car channel, with additional corner reinforcement plates. All wall panels are 1/4" thick plate steel and adjacent to blade area is 12" high reinforcement impact area of 1/2" thick steel. Fluffer dimensions are custom fit to opening size specified by customer's baler.

The main door assembly is fabricated from 1/2" structural steel and a 1/2" thick angle frames the door panel. A 2 15/16" hinge pin is encased in (5) 3/4" wall mechanical tubings with 3 bronze bushings.

Blade is fabricated from 1-1/2" thick plate steel.

ASSEMBLY AND FINISH:

All welding procedures follow the guidelines set forth by AWS section D1.1. Standard welding is either ARC or MIG, depending on application.

Equipment finish includes cleaning all surfaces of grease, oil, etc. as well as an inspection to remove sharp edges. Each sub-assembly receives one coat of 2 1/2 mils DFT industrial enamel paint. Finish paint color may be specified by customer.

FOR HYDRAULIC ACTUATED DOORS ONLY:

Movement of the doors and locks are controlled with hydraulic cylinders and self-contained hydraulic power pack. All cylinders are rated at maximum 3000 PSI.

All drive components are assembled, tested, guarded, and shipped as an integral part of the Fluffer, unless specified.

The Engineering Department at Karl W. Schmidt & Associates, Inc. incorporates all the elements required to provide our customers with the equipment or system which will best suit the unique conditions of their operation. The engineering staff includes the Department Manager, Senior Project Manager, Designers, Electrical Designer and drafting personnel.

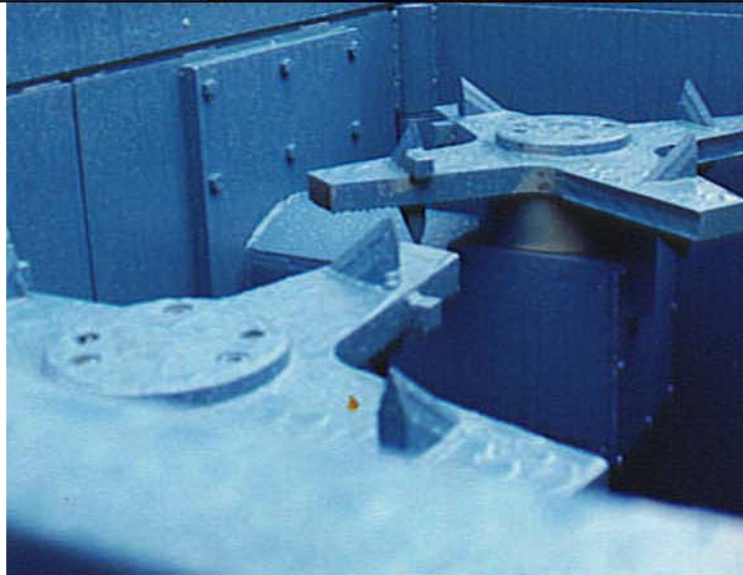

SECURE MANUAL DOOR IN OPEN POSITION.

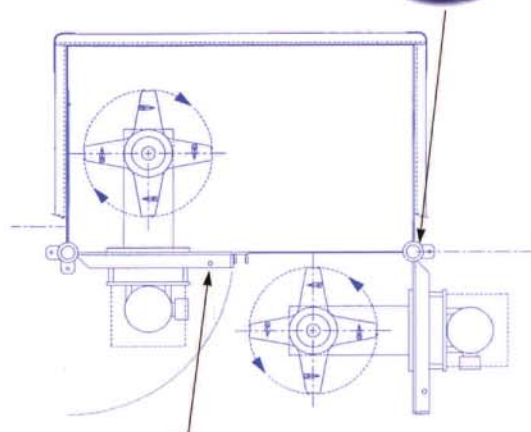

DOOR CLOSED WITH LIMIT SWITCH ACTIVATED.